

INSTALLATION INSTRUCTIONS

MAGNETICTM 600

MEDIUM CONVOLUTED DIAPHRAGM INSTRUMENTS DIFFERENTIAL PRESSURE GAUGE/SWITCH

For efficient working of your instrument, please read all instructions carefully before attempting to install.

Operating principle

High and Low pressures are separated by a sensor assembly consisting of a magnet, diaphragm and a range spring. The difference in pressure causes the sensor assembly to move in proportion to the change against a range spring.

A rotary magnet, located in a separate body compartment and isolated from the acting pressures, is rotated by magnetic coupling as per the linear movement of the sensor assembly. A pointer attached to the rotary magnet indicates differential pressure on the dial.

Switch operation : Reed switches are located adjacent to the pressure chamber and are activated by the magnetic field of the sensor assembly.

Note : These instruments are calibrated to give $\pm 3\%$ full scale accuracy on ascending readings.

Caution : Do not exceed max. operating pressure given on the instrument label. The instrument is for use with air or compatible gases only. Do not mount the gauge at locations where instrument is subjected to vibrations.

Installation

For better performance the instrument should be mounted horizontally by keeping the dial vertical.

Depressurize the system and connect the high and low pressure lines of your system to the " High" \oplus & "Low" \ominus ports of the instrument, respectively.

High pressure : Connect tubing from source of high pressure to either of the two high pressure ports. Plug the port which is not used.

Low pressure : Connect tubing from source of low pressure to either of the two low pressure ports. Plug the port which is not used.

The instrument is now ready for operation.

Apply "High" and "Low" pressures simultaneously, to avoid damage to the internal parts.

MAGNETIC 600 consists of a convoluted diaphragm to sense the pressure difference. It can withstand maximum operating pressure up to 35 psi / 2.4 bar and temperature up to 60°C / 140°F max. for all ranges.

If pressure exceeds the rated maximum pressure, "O" rings & diaphragm inside the pressure chamber, will be damaged. If maximum operating pressure is within the allowable limit of 35 psi / 2.4 bar, but the differential pressure exceeds instrument range, there will be no damage to the instrument. Pointer will only go the extreme right end of the scale.

The pointer will always remain in the dead band marked at the beginning of the scale. Calibration or adjustment of pointer is not recommended unless until the pointer is outside the dead band.

For minor calibration arrangement, turn the pre-compression screw clockwise or counter clockwise. Do not attempt to open / repair the gauge.



MANOMETER (INDIA) Pvt. Ltd.
MANU MANSION,
16, SHAHID BHAGATSINGH ROAD,
MUMBAI - 400 023.
Tel. : 2266 2076 / 2266 2942
Fax: 91 - 22 -2266 2397
E-mail: manometer@vsnl.com
www.manometerindia.com

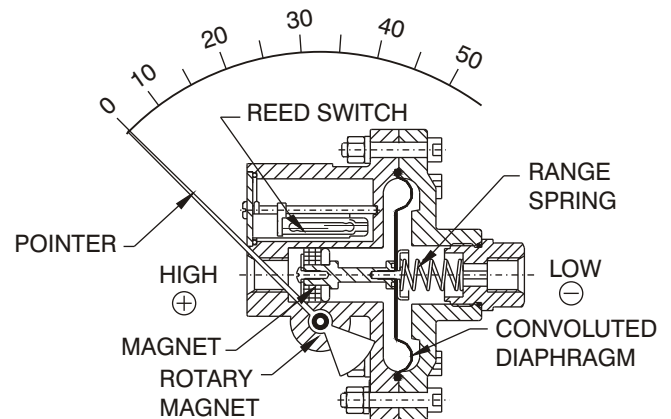

Precautions

Do not connect "High" and "Low" ports to wrong pipe ends. Do not subject the instrument to excessive vibration.

Field repairs are not recommended, because if not reassembled properly calibration will be affected.

Standard accessories – Two 1/8" NPT (M) adaptors for tube connection to inline or back ports. Two 1/8 NPT (M) plugs to plug the ports not in use. Three screws, each of M3 x 4 and M3 x 20 for flush mounting along with three flush mounting clamps are provided.

For surface mounting option : For surface mounting, a surface mounting plate with two spacers is supplied.

Trouble shooting:

If Magnetic gauge does not show reading or shows incorrect reading.

See that the unused ports are properly plugged.

Pressure tabs / tubings are connected without leaks, blocks or twists.

Installation not done as per the recommended procedure.

Foreign / magnetic particle have entered the sensing chamber.

If problem is not resolve by referring to the information above, contact supplier.

SWITCH SETTING

Please follow these instructions when your differential pressure instruments are supplied with switch.

CAUTION : Supply should not exceed switch rating. For higher supply, use of relay circuit is recommended.

Switch adjustment

Switch adjustment screw is located on plastic cover.

Rotate the screw anti-clockwise to increase the set point and clockwise to decrease the set point.

One or two trials may be necessary to attain the exact set point.

Above procedure to be followed by putting the instrument on test bed or while in actual service.

NOTE : Instrument and switch has IP65 protection

View from high pressure side



Increase set point
anti-clockwise

SPST SWITCH

Specifications

Contact Rating : 10 VA AC (rms) or DC (max)
Switching Current : 0.5 Amp AC (rms) or DC (max)
Switch Voltage : 150 V AC (rms) or DC (max)

One SPST switch

Reed switches & Din plug connection

View of socket for supply connections

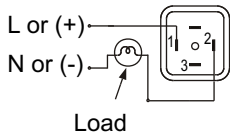

View of plug after removing the socket

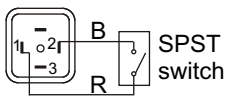

Two SPST switches

Reed switches & Din plug connection

View of socket for supply connections

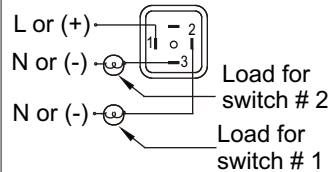

View of plug after removing the socket

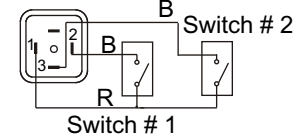

FLUSH MOUNTING

Flush mounting kit contains three each of M3X4 and 3 self tapping screws with three flush mounting clamps.

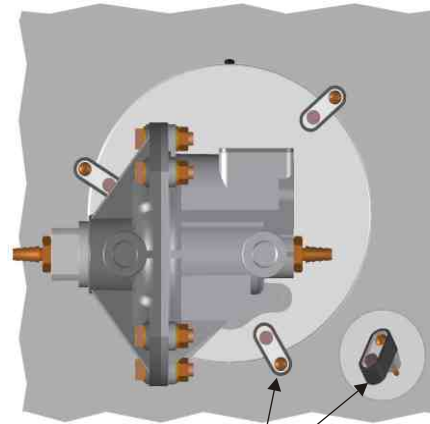

Panel cutout \varnothing 115 mm

Flush mounting clamp

SPDT SWITCH

Specifications

Contact Rating : 5 VA AC (rms) or DC (max)
Switching Current : 0.25 Amp AC (rms) or DC (max)
Switch Voltage : 175 V AC (rms) or DC (max)

One SPDT switch

Reed switches & Din plug connection

View of socket for supply connections

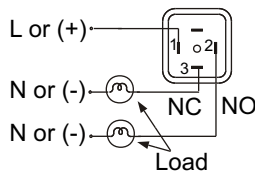

View of plug after removing the socket

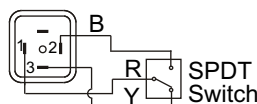

R=Red, B=Black, Y=Yellow, L=Live or +ve supply, N=Nutral or -ve supply

SURFACE MOUNTING (OPTIONAL)

Surface mounting plate along with fasteners is supplied.

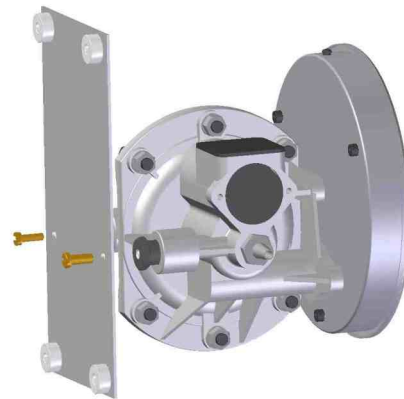

Seal back ports with metal plugs supplied and clamp the plate with two M4 X10 screws on tapped holes of plugs.