

## PISTON OR DIAPHRAGM SENSORS



Manometer India manufactures quality explosion proof differential pressure instruments are used in environment containing hazardous vapours, gases, or particulates.

Switches and electrical connections are mounted in special UL, CSA, FM, CENELEC approved enclosure. The cast Aluminium housing has a provision of two mounting slots, two 3/4" NPT electrical conduit ports.

### They meet following specifications:

Class I, Gr. B, C & D, Class II, Gr. E, F & G; and Class III. They also meet NEMA 3, 4X, 7, 9 & 12 specifications.

The instruments can be equipped with 1 or 2 SPST or SPDT reed switches.

### APPLICATIONS :

Hazardous locations in petrochemical industries, process industries, explosive conditions, and oilfield sectors.

## EXPLOSION PROOF

### SALIENT FEATURES

- Cost effective and reliable.
- Simple and compact design.
- Available in piston and diaphragm sensors
- Adjustable reed contact switching.
- Gauge+ switch or only switch models.
- Manufactured in ISO 9002 certified plant.
- Exported worldwide.



**MANOMETER (INDIA) Pvt. Ltd.**  
MANU MANSION,  
16, SHAHID BHAGATSINGH ROAD,  
MUMBAI - 400 023.  
Tel. : 2266 2076 / 2266 2942  
Fax: 91 - 22 - 2266 2397  
E-mail: manometer@vsnl.com  
www.manometerindia.com

# MAGNETIC PRINCIPLE

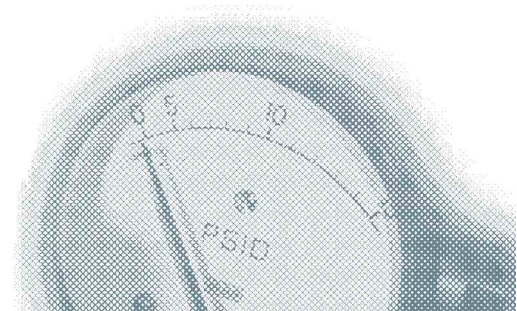

## OPERATING PRINCIPLE

Variations in pressure between high and low ports is sensed by a piston or diaphragm sensor which moves in proportion to the pressure difference. A primary magnet is attached to the sensor and moves with it in the same proportion. A rotary magnet with pointer is magnetically coupled with the primary magnet, and is situated in an isolated cavity. Movement of rotary magnet with pointer indicates differential pressure on the dial. Process fluids are isolated from dial case and switch enclosure.

An auxiliary magnet situated in the tube extension also moves with the pressure sensors. Reed switches mounted on the extension tube are activated due to interaction between switch contacts and field of auxiliary magnet. Switches can be adjusted to open or close at preset points.

## EXPLOSION PROOF INSTRUMENTS

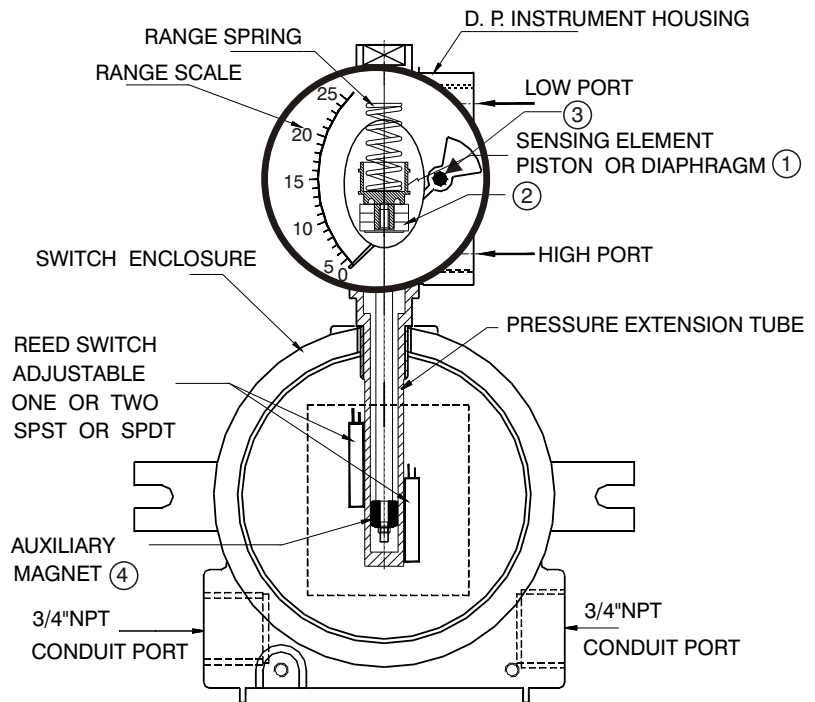

## TECHNICAL DATA

Explosion proof differential pressure instruments are same as our standard differential pressure instruments where high pressure side is modified with an extension tube and is housed in an explosion proof box in which switches are also located.

Model	200 DPG	200 DGR	300 DGC
Sensor	Piston	Rolling diaphragm	Small convoluted diaphragm
Max. Operating pressure	200 bar / 3000 psi	200 bar / 3000 psi	100 bar / 1500 psi
Max. Differential pressure	10 bar / 150 psi	7 bar / 100 psi	4 bar / 60 psi

## HOW TO ORDER

Select a model from individual model data sheets and add “EX” at the beginning of the product code. Also indicate if it is required with or without explosion proof box.

**Limitations :** 1) As per individual data sheets.

2) We do not recommend flange mounting as explosion box is heavy ( 1.40 kg / 3.10 Lbs. )

3) High and Low ports are on the right side only, however back connections can also be given.

## STANDARD DIMENSIONS FOR EXPLOSION PROOF INSTRUMENT (MODEL EX 200 DPG)

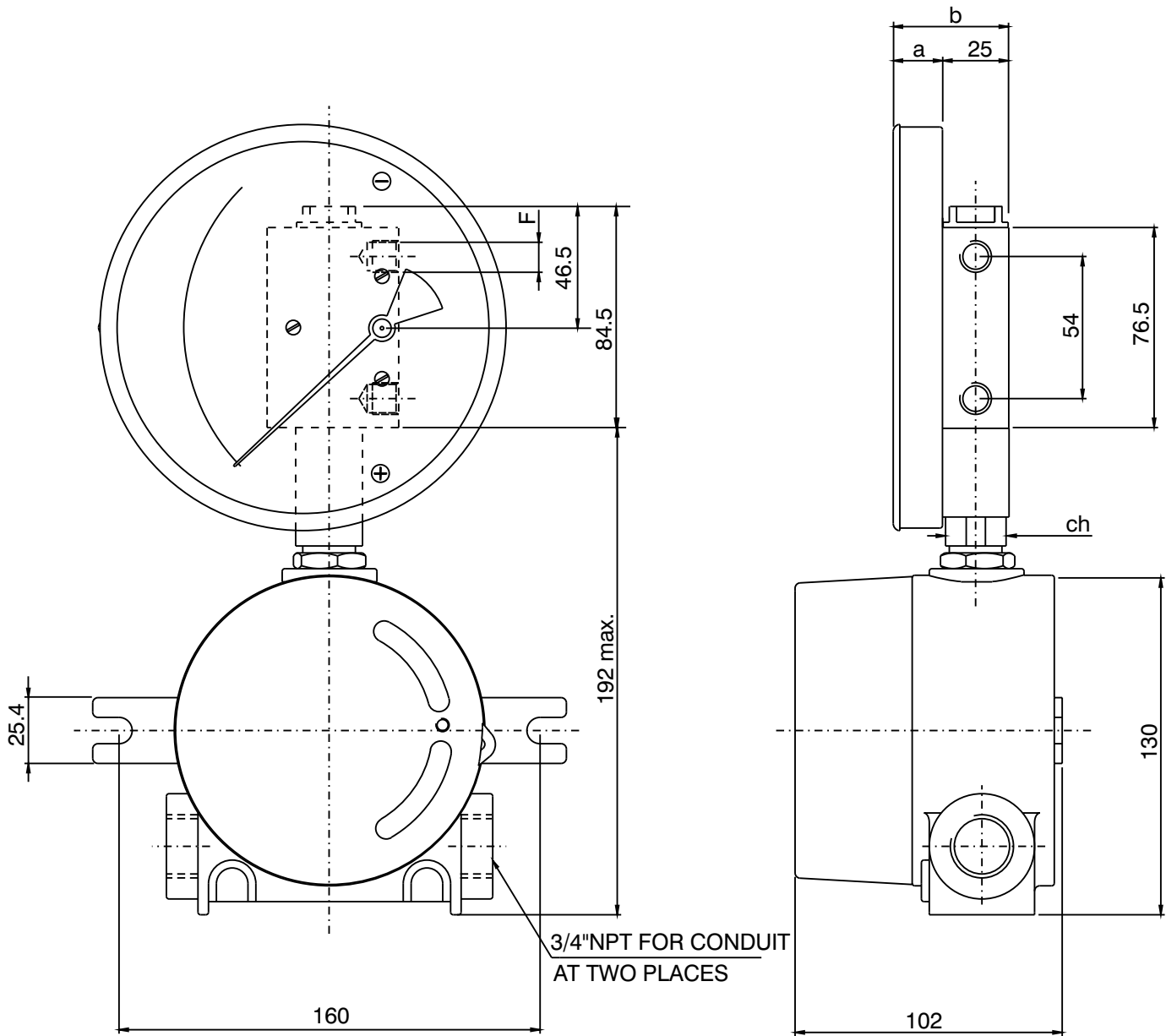

DIAL Ø	F	a	b	d	ch
80 (3.5")	1/4" BSP - 1/4" NPT	19	44	83.0	22
100 (4.0")	1/4" BSP - 1/4" NPT	19	44	104.3	22
115 (4.5")	1/4" BSP - 1/4" NPT	19	44	119.7	22
150 (6.0")	1/4" BSP - 1/4" NPT	19	44	154.3	22

## STANDARD DIMENSIONS FOR EXPLOSION PROOF INSTRUMENT (MODEL EX 200 DGR)

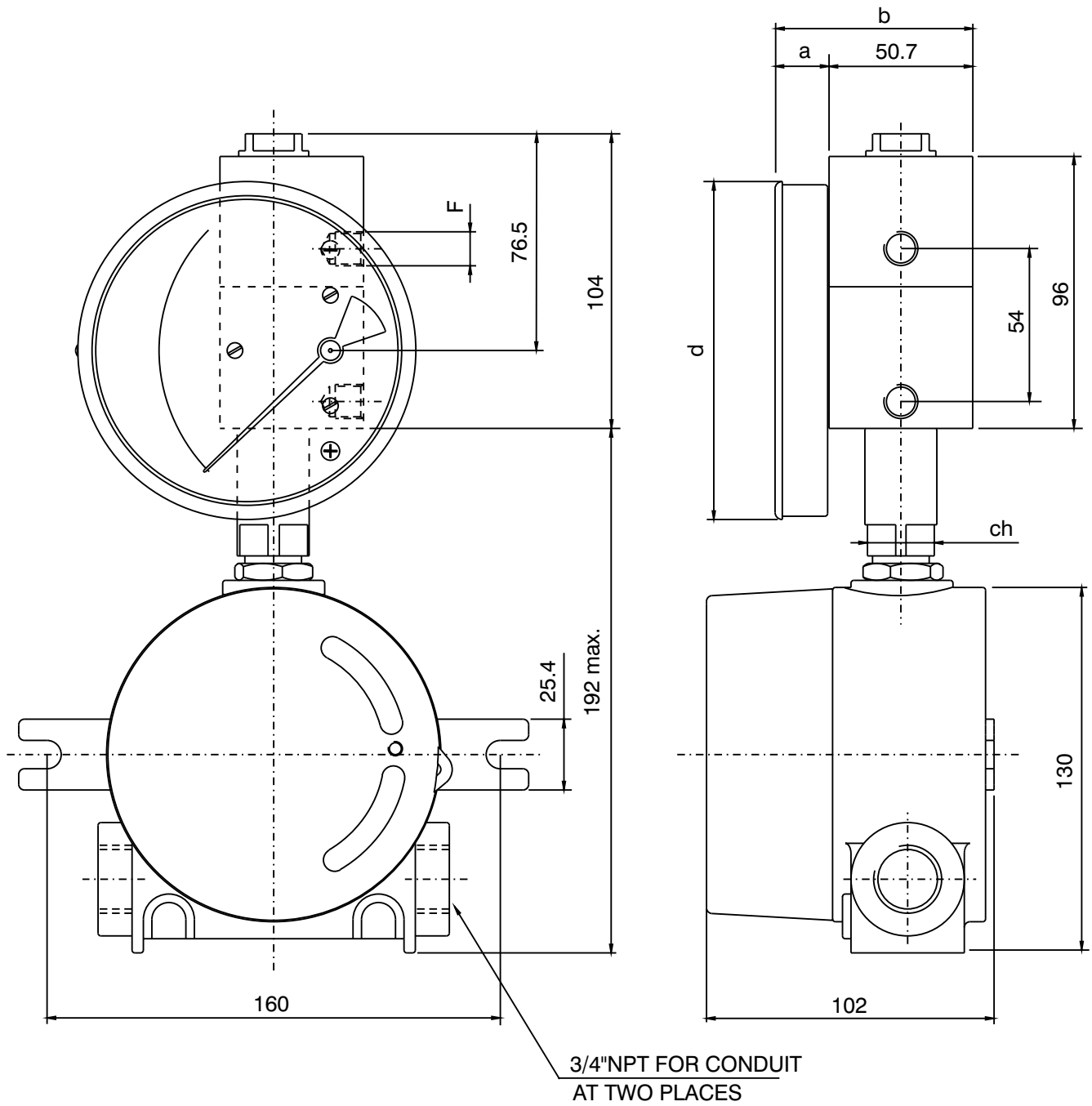

DIAL Ø	F	a	b	d	ch
80 (3.5")	1/4" BSP - 1/4" NPT	19	69.7	83.0	22
100 (4.0")	1/4" BSP - 1/4" NPT	19	69.7	104.3	22
115 (4.5")	1/4" BSP - 1/4" NPT	19	69.7	119.7	22
150 (6.0")	1/4" BSP - 1/4" NPT	19	69.7	154.3	22

## STANDARD DIMENSIONS FOR EXPLOSION PROOF INSTRUMENT (MODEL EX 300 DGC)

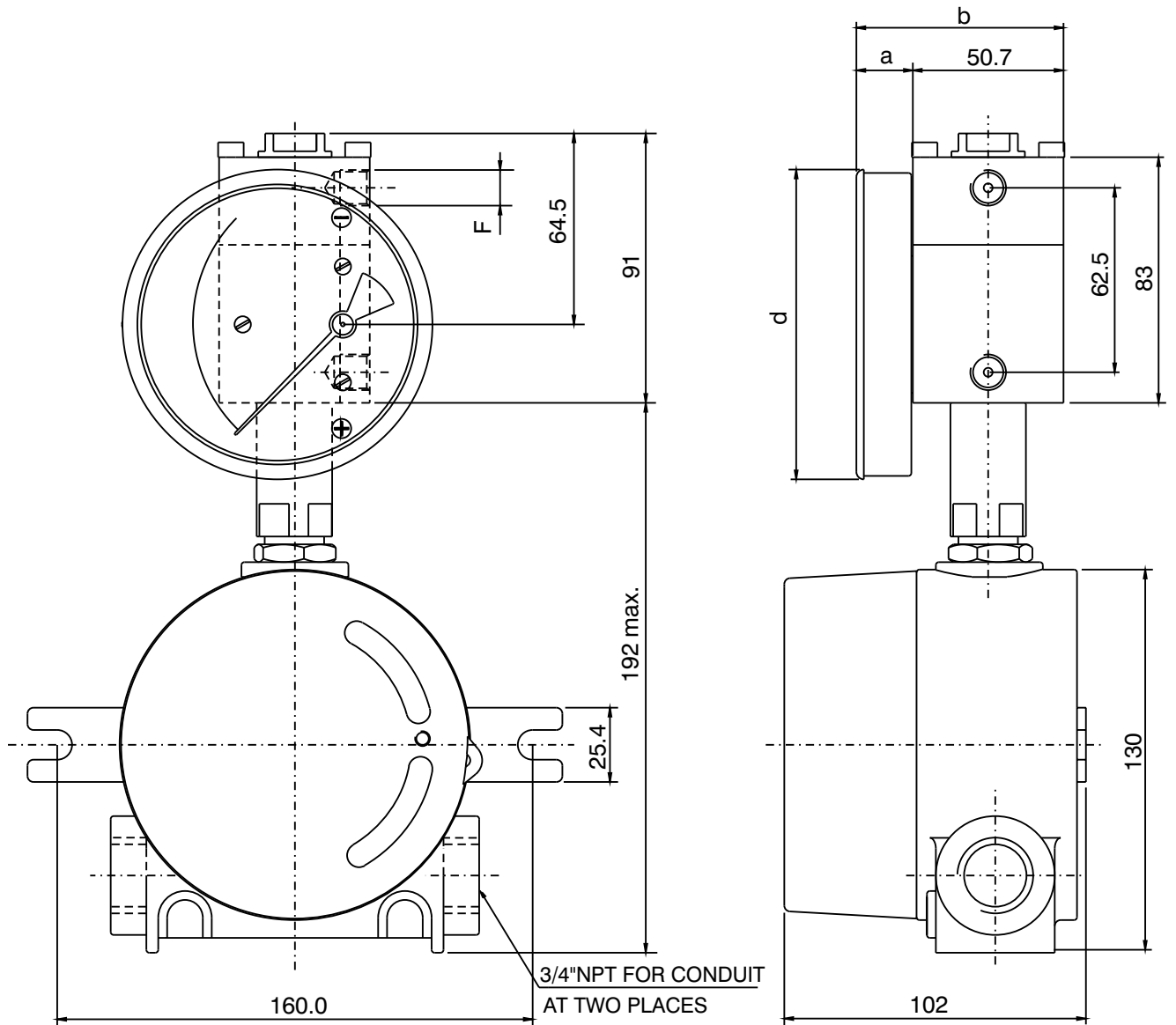

DIAL Ø	F	a	b	d	ch
80 (3.5")	1/4" BSP - 1/4" NPT	19	69.7	83.0	22
100 (4.0")	1/4" BSP - 1/4" NPT	19	69.7	104.3	22
115 (4.5")	1/4" BSP - 1/4" NPT	19	69.7	119.7	22
150 (6.0")	1/4" BSP - 1/4" NPT	19	69.7	154.3	22