

INSTALLATION INSTRUCTIONS

Explosion Proof

PISTON / DIAPHRAGM INSTRUMENTS

DIFFERENTIAL PRESSURE INSTRUMENTS

For efficient working of your instrument, please read all instructions carefully before attempting to install.

CAUTION : Do not exceed maximum operating pressure given on the instrument label.

Check fluid compatibility with wetted parts before use.

OPERATING PRINCIPLE

Variations in pressure between high and low ports is sensed by a piston or diaphragm sensor which moves in proportion to the pressure difference. A primary magnet is attached to the sensor and moves with it in the same proportion. A rotary magnet with pointer is magnetically coupled with the primary magnet, and is situated in an isolated cavity. Movement of rotary magnet with pointer indicates differential pressure on the dial. Process fluids are isolated from dial case and switch enclosure.

SWITCH : An auxiliary magnet situated in the tube extension moves with the pressure sensors. Reed switches mounted on the extension tube are activated due to interaction between switch contacts and field of auxiliary magnet. Switches can be adjusted to open or close at preset points.

Note : The instruments are calibrated to give $\pm 2\%$ full scale accuracy on ascending readings.

INSTALLATION

The instrument has entry ports at side. Depressurize the system and connect the high and low pressure lines of your system to the "High" \oplus & "Low" \ominus ports of the instrument, respectively.

It is recommended to use "O" rings with male connectors to avoid excessive tightening and to prevent leakage (For parallel threads). The instrument is now ready for operation.

Apply "High" and "Low" pressures simultaneously, to avoid damage to the internal parts.

If pressure exceeds the rated maximum pressure, "O" rings used on male connectors, and the teflon seal inside the pressure chamber of piston instrument will be damaged. In diaphragm instrument diaphragm may rupture. If maximum operating pressure is within the allowable limit, but the differential pressure exceeds instrument range, there will be no damage to the instrument. Pointer will only go the extreme right end of the scale.



MANOMETER (INDIA) Pvt. Ltd.
MANU MANSION,
16, SHAHID BHAGATSINGH ROAD,
MUMBAI - 400 023.
Tel. : 2266 2076 / 2266 2942
Fax: 91 - 22 - 2266 2397
E-mail: manometer@vsnl.com
www.manometerindia.com

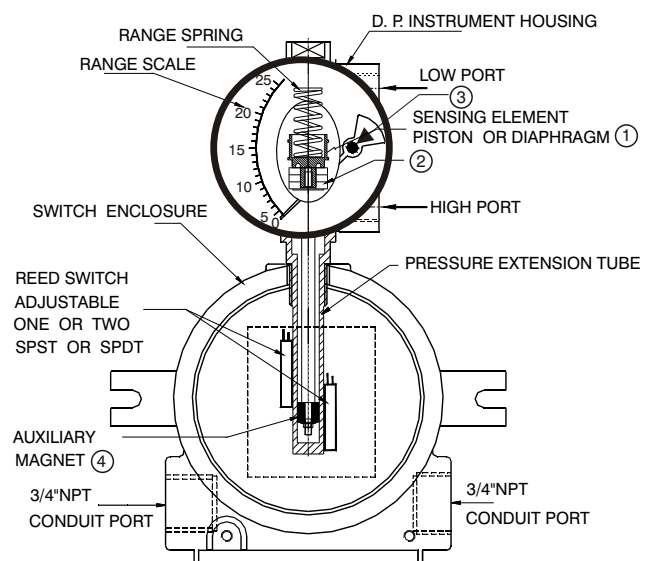

PRECAUTIONS

Do not connect "High" and "Low" ports to wrong pipe ends. Do not subject the instrument to excessive vibration.

The instrument is never to be used in an area where a magnetic field is present. It may show wrong readings.

As the instrument works on magnetic coupling, use only non magnetic fittings, parts etc. in areas closer than 50 mm on all sides, Otherwise calibration will get effected.

Do not try to open any part of the instrument for any reason, because if not reassembled properly calibration will be affected.

SWITCH SETTING (Explosion Proof)

The switches are normally factory set to save time at customer's end. However they are field adjustable.

CAUTION : Supply should not exceed switch rating.
For higher supply, use of relay circuit is recommended.

SWITCH ADJUSTMENT

Unscrew the cover of electrical enclosure & keep it aside. Knurled head screws are provided at bottom for adjustment.

Rotate the screw anti-clockwise to decrease the set point and clockwise to increase the set point.

One or two trials may be necessary to attain the exact set point.

Above procedure to be followed by putting the instrument on test bed or while in actual service.



SPST SWITCH

Specifications

Contact Rating : 10 VA AC (rms) or DC (max)
Switching Current : 0.5 Amp AC (rms) or DC (max)
Switch Voltage : 150 V AC (rms) or DC (max)

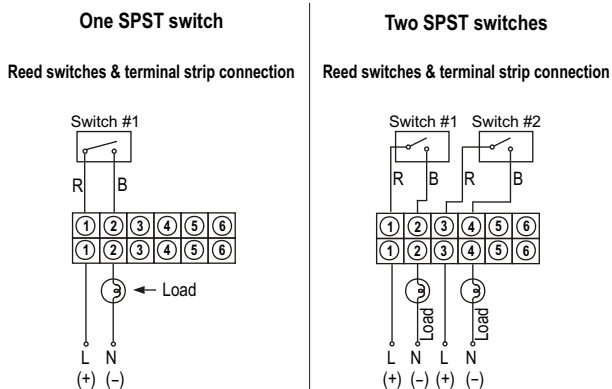

SPDT SWITCH

Specifications

Contact Rating : 5 VA AC (rms) or DC (max)
Switching Current : 0.25 Amp AC (rms) or DC (max)
Switch Voltage : 175 V AC (rms) or DC (max)

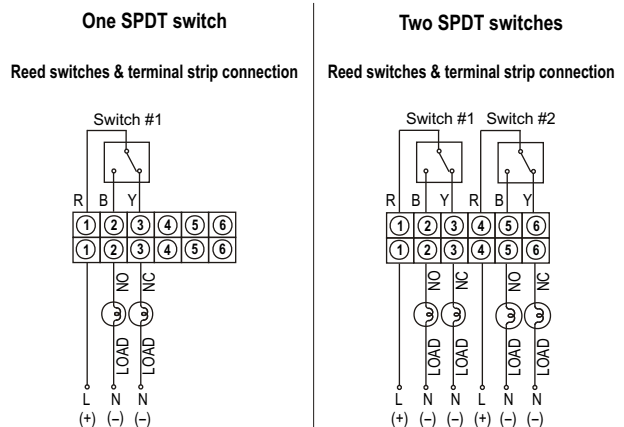

R=Red, B=Black, Y=Yellow, L=Live or +ve supply, N=Nutral or -ve supply

* Body to be suitably earthed while using gauge + switch and only switch.